

SOIL EROSION AND SEDIMENT CONTROL

- All soil erosion and sediment control practices will be installed in accordance with the New Jersey Standards for Soil Erosion and Sediment Control and will be installed in proper sequence and maintained until permanent protection is established.
- Any disturbed area that will be left exposed for more than thirty (30) days and not subject to construction traffic shall immediately receive a temporary seeding. If the season prohibits temporary seeding, the disturbed area will be mulched with salt hay or equivalent and be anchored in accordance with the NJ Standards (i.e. peg and twine, mulch netting, or liquid mulch binder).
- Immediately following initial disturbance or rough grading, all critical areas subject to erosion will receive a temporary seeding in combination with straw mulch or a suitable equivalent at a rate of 2 tons per acre, according to the NJ Standards.
- Stabilization Specifications - Temporary Seeding and Mulching:
 - Lime - 90 lbs/1,000 sf ground limestone; Fertilizer - 14 lbs/1,000 sf or equivalent worked into soil a minimum of 4".
 - Seed - Annual Ryegrass 40 lbs/acre or other approved seeds; plant between March 1 and May 15 or between August 15 and October 1.
 - Mulch - salt hay or small grain straw at a rate of 70 to 90 lbs/1,000 sf to be applied according to the NJ Standards. Mulch shall be secured by approved methods (i.e. peg and twine, mulch netting, or liquid mulch binder).
- A sub-base course will be applied immediately following rough grading and installation of improvements in order to stabilize driveways. In areas where no utilities are present, sub-base will be installed within 15 days of preliminary grading.
- The site shall at all times be graded and maintained such that all stormwater run-off is diverted to soil erosion and sediment control facilities.
- Any steep slopes receiving pipeline installation will be backfilled and stabilized daily, as the installation proceeds (i.e. slopes greater 3:1).
- All sedimentation structures will be inspected and maintained on a regular basis.
- Maximum side slopes of all exposed surfaces shall not exceed 2:1 unless otherwise approved by the district.
- Any individual access roads or drives must be stabilized with 2- 1/2" crushed stone prior to commencement of construction in that area.
- Paved roadways must be kept clean at all times.
- All catch basin inlets must be protected with a crushed stone or hay bale filter (see detail).
- Permanent vegetation to be seeded or sodded on all exposed areas within ten (10) days after final grading. Mulch to be used as necessary for protection until seeding is established.
- Permanent Stabilization Specifications: Seeding

Perennial Ryegrass	1/2 lb/1,000 sf
Kentucky Bluegrass	1 lb/1,000 sf
Red Fescue	1/2 lb/1,000 sf
Spreading Fescue	1/2 lb/1,000 sf
Lime	90 lb/1,000 sf
Fertilizer	14 lb/1,000 sf
- Permanent Stabilization Specifications: Mulching
 - Mulch materials to be unrotted salt hay, hay or small grain straw at the rate of 1.5 to 2 tons per acre or 70 to 90 pounds per 1,000 sq. ft.
 - Spread uniformly by hand or mechanically so that approximately 75% to 95% of soil surface will be covered.
 - Mulch anchoring to be done immediately after placement by one of the following methods: Peg and twine; Mulch netting; Liquid mulch - binders.
- All unstabilized areas to be sprinkled with water until wet at the beginning of each day to control dust.
- Any soil having a pH of 4 or less or containing iron sulfides shall be covered with a minimum of 12" of soil having a pH of 5 or more prior to seedbed preparation.
- At the time of site preparation for permanent vegetative stabilization, any soil not suitable to support adequate vegetative ground cover will be removed or treated in such a way to permanently adjust the soil conditions and render it suitable for vegetative ground cover. (If removal or treatment of the soil will not provide suitable conditions, non-vegetative means of permanent ground stabilization will have to be provided).
- The Soil Conservation District may request additional measures to minimize on or off-site erosion problems during construction. The District shall be notified in writing 72 hours prior to the commencement of any land disturbance.
- Any changes to the certified Soil Erosion and Sediment Control Plans will require the submission of revised Soil Erosion and Sediment Control Plans to the District for recertification. The revised plans must meet all current and State Soil Erosion and Sediment Control Standards.

SEQUENCE OF CONSTRUCTION

- | | |
|---|---------|
| 1. INSTALL ALL SOIL EROSION & SEDIMENT CONTROL MEASURES | 2 DAYS |
| 2. STRIP TOPSOIL AND STOCKPILE, INSTALL SILT FENCE ON LOW SIDE AND TEMPORARY SEED | 4 DAYS |
| 3. ROUGH GRADE ROAD | 10 DAYS |
| 4. INSTALL SANITARY SEWER SYSTEM | 14 DAYS |
| 5. INSTALL STORM WATER MANAGEMENT SYSTEM INCLUDING DETENTION BASIN | 14 DAYS |
| 6. INSTALL GRANITE BLOCK CURB | 4 DAYS |
| 7. INSTALL BASE COURSE OF PAVEMENT | 3 DAYS |
| 8. BEGIN BUILDING CONSTRUCTION | 1 YEAR |
| 9. FINE GRADE AND SEED SITE | 2 DAYS |
| 10. INSTALL FINAL COURSE OF PAVEMENT | 2 DAYS |
| 11. REMOVE ALL SOIL EROSION & SEDIMENT CONTROL MEASURES | 2 DAYS |

DUST CONTROL

WHEN REQUIRED ONE OR MORE OF THE FOLLOWING METHODS SHALL BE USED FOR DUST CONTROL:

MULCHES - SEE NOTES FOR TEMPORARY STABILIZATION

VEGETATIVE COVER - SEE NOTES FOR TEMPORARY AND PERMANENT STABILIZATION

SPRAY-ON ADHESIVES - ON MINERAL SOILS (NOT EFFECTIVE ON MUCK SOILS) KEEP TRAFFIC OFF THESE AREAS

	WATER DILUTION	TYPE OF NOZZLE	APPLY GAL/ACRE
ANIONIC ASPHALT EMULSION	7:1	COARSE SPRAY	1,200
LATEX EMULSION	12.5:1	FINE SPRAY	235
RESIN IN WATER	4:1	FINE SPRAY	300
POLYACRYLAMIDE (PAM) - SPRAY ON	APPLY ACCORDING TO MANUFACTURER'S INSTRUCTIONS. MAY ALSO BE USED AS AN ADDITIVE TO SEDIMENT BASINS TO FLOCCULATE AND PRECIPITATE SUSPENDED COLLOIDS. SEE SEDIMENT BASIN STANDARD		
POLYACRYLAMIDE (PAM) - DRY SPRAY			
ADJULATED SOY BEAN SOAP STICK	NONE	COARSE SPRAY	1200

TILLAGE - TO LOUPTEN SURFACE AND BRING CLODS TO THE SURFACE. THIS IS A TEMPORARY EMERGENCY MEASURE WHICH SHOULD BE USED BEFORE SOIL BLOWING STARTS. BEGIN PLOWING ON WINDWARD SIDE OF SITE. CHisel-TYPE PLOWS SPACE ABOUT 12 INCHES APART, AND SPRING-TOOTHED HARROWS ARE EXAMPLES OF EQUIPMENT WHICH MAY PRODUCE DESIRED EFFECT.

SPRINKLING - SITE IS SPRINKLED UNTIL THE SURFACE IS WET.

BARRIERS - SOLID BOARD FENCES, SNOW FENCES, BURLAP FENCES, CRATE WALLS, BALES OF HAY, AND SIMILAR MATERIAL CAN BE USED TO CONTROL AIR CURRENTS AND SOIL BLOWING.

CALCIUM CHLORIDE - SHALL BE IN THE FORM OF LOOSE, DRY GRANULES OR FLAKES FINE ENOUGH TO FEED THROUGH COMMONLY USED SPREADERS AT A RATE THAT WILL KEEP SURFACE MOIST BUT NOT CAUSE POLLUTION OR PLANT DAMAGE. IF USED ON STEEPER SLOPES, THEN USE OTHER PRACTICES TO PREVENT WASHING INTO STREAMS OR ACCUMULATION AROUND PLANTS.

STONE - COVER SURFACE WITH CRUSHED STONE OR COARSE GRAVEL.

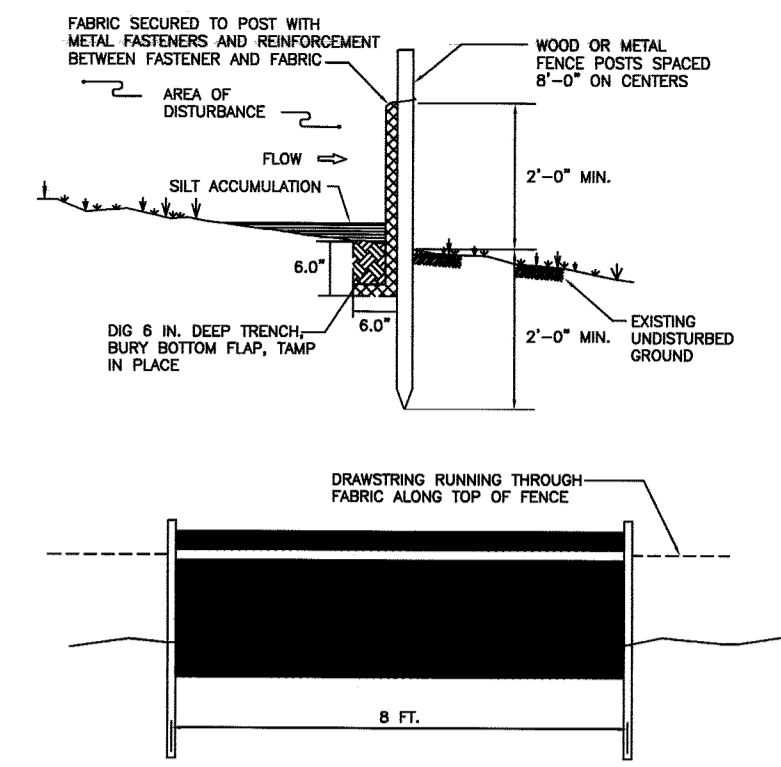

REQUIREMENTS FOR SILT FENCE:

- FENCE POSTS SHALL BE SPACED 8 FEET CENTER-TO-CENTER OR CLOSER. THEY SHALL EXTEND AT LEAST 2 FEET INTO THE GROUND AND EXTEND AT LEAST 2 FEET ABOVE GROUND (VIA 2x2 POSTS SHALL BE CONSTRUCTED OF HARDWOOD WITH A MINIMUM DIAMETER THICKNESS OF 1 1/2 INCHES).
- A METAL FENCE WITH 8 INCH OR SMALLER OPENINGS AND AT LEAST 2 FEET HIGH MAY BE UTILIZED, FASTENED TO THE FENCE POSTS, TO PROVIDE REINFORCEMENT AND SUPPORT TO THE GEOTEXTILE FABRIC WHERE SPACE FOR OTHER PRACTICES IS LIMITED AND HEAVY SEDIMENT LOADING IS EXPECTED.
- A GEOTEXTILE FABRIC RECOMMENDED FOR SUCH USE BY THE MANUFACTURER SHALL BE BURIED AT LEAST 8 INCHES DEEP IN THE GROUND. THE FABRIC SHALL EXTEND AT LEAST 2 FEET ABOVE THE GROUND. THE FABRIC MUST BE SECURELY FASTENED TO THE POSTS USING A SYSTEM CONSISTING OF METAL FASTENERS (NAILS OR STAPLES) AND A HIGH STRENGTH REINFORCEMENT MATERIAL (WIRE MESH, GEOMETRIC WIRE MESH, ETC.) PLACED BETWEEN THE FASTENER AND THE GEOTEXTILE FABRIC. THE FASTENING SYSTEM SHALL RESIST TEARING AWAY FROM THE POST. THE FABRIC SHALL INCORPORATE A DRAWSTRING IN THE TOP PORTION OF THE FENCE FOR ADDED STRENGTH.

SILT FENCE
NOT TO SCALE

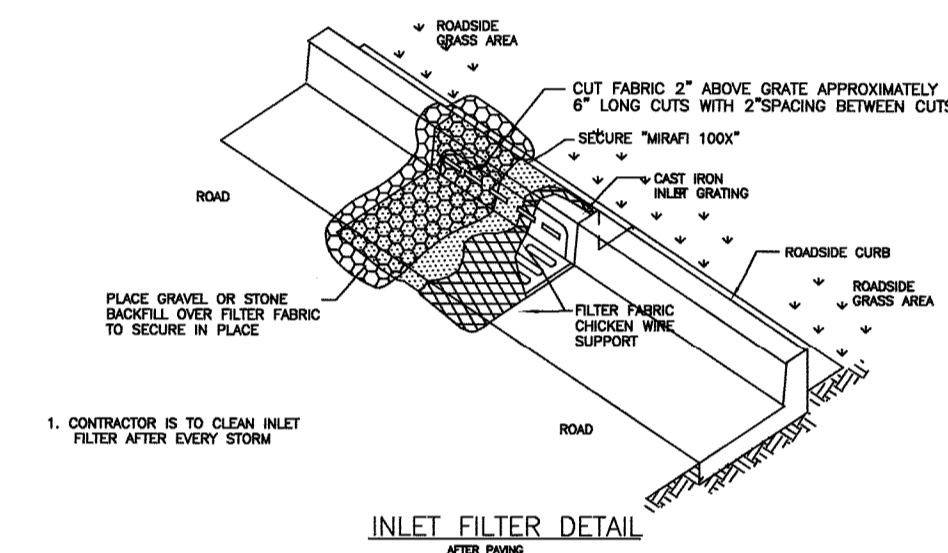

INLET FILTER DETAIL
NOT TO SCALE

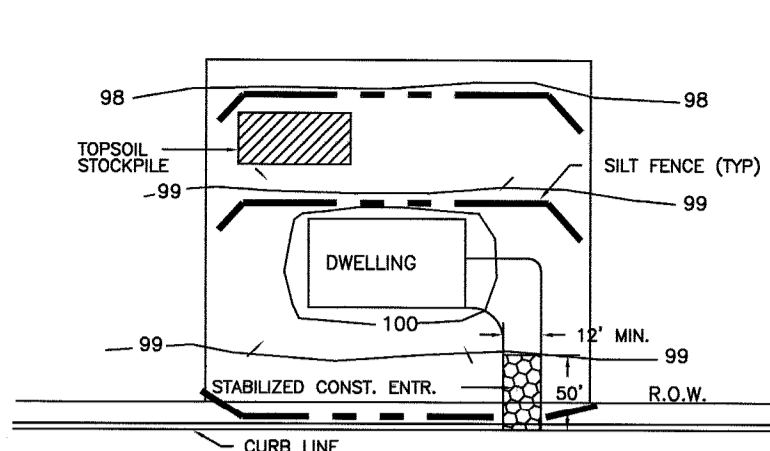

NOTES:

- STABILIZED CONSTRUCTION ENTRANCE SHALL BE PROVIDED IN ACCORDANCE WITH THE STABILIZED CONSTRUCTION ENTRANCE DETAIL EXCEPT FOR THE DIMENSIONS SHOWN ABOVE.
- THE STOCKPILE SHALL BE CONSTRUCTED IN ACCORDANCE WITH THE TOPSOIL STOCKPILE DETAIL.
- ALL SILT FENCE SHALL BE PROVIDED IN ACCORDANCE WITH THE SILT FENCE DETAIL. SILT FENCE SHALL BE PROVIDED ON THE DOWNHILL SIDE OF ANY AND ALL DISTURBANCE.
- ANY DISTURBED AREA REMAINING DISTURBED FOR MORE THAN 30 DAYS SHALL BE STABILIZED.
- ALL DISTURBED AREAS SHALL BE STABILIZED IN ACCORDANCE WITH THE MINIMUM STABILIZATION REQUIREMENTS FOR PERMANENT STABILIZATION PRIOR TO RECEIVING A CERTIFICATE OF OCCUPANCY.

TYPICAL LOT UNDER CONSTRUCTION
NOT TO SCALE

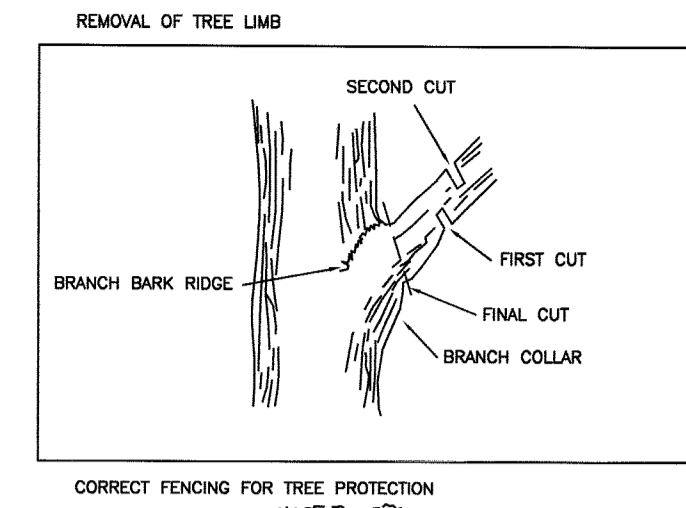

REMOVAL OF TREE LIMB

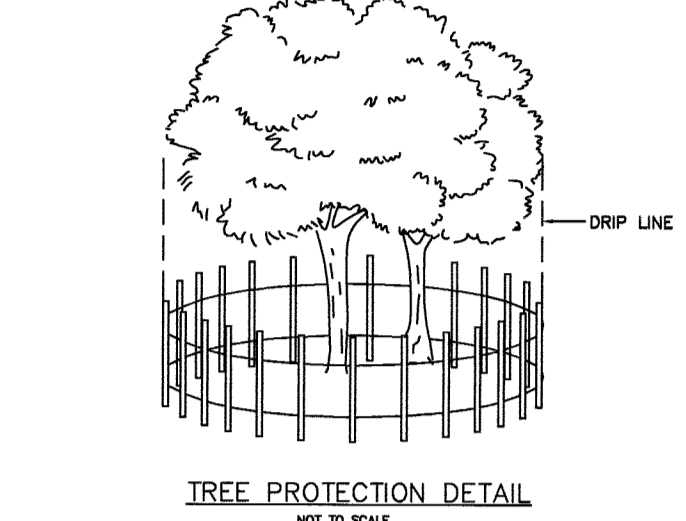

TREE PROTECTION DETAIL
NOT TO SCALE

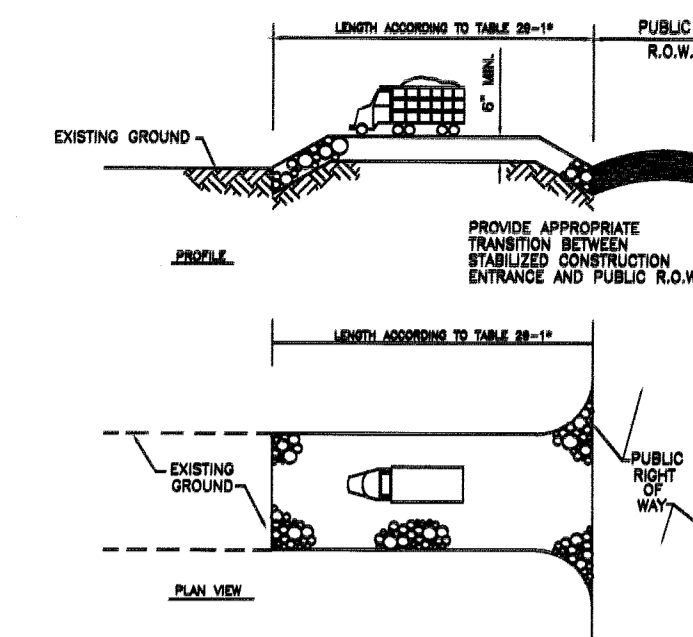

STABILIZED CONSTRUCTION ACCESS
NOT TO SCALE

PERCENT SLOPE OF ROADWAY	LENGTH OF STONE REQUIRED	COARSE GRANULATED SOILS	FINE GRANULATED SOILS
0-2%	50 FT.	100 FT.	100 FT.
2-5%	100 FT.	200 FT.	200 FT.
5-8%	ENTIRE SURFACE STABILIZED WITH FABR BASE COURSE		

SUPER SILT FENCE

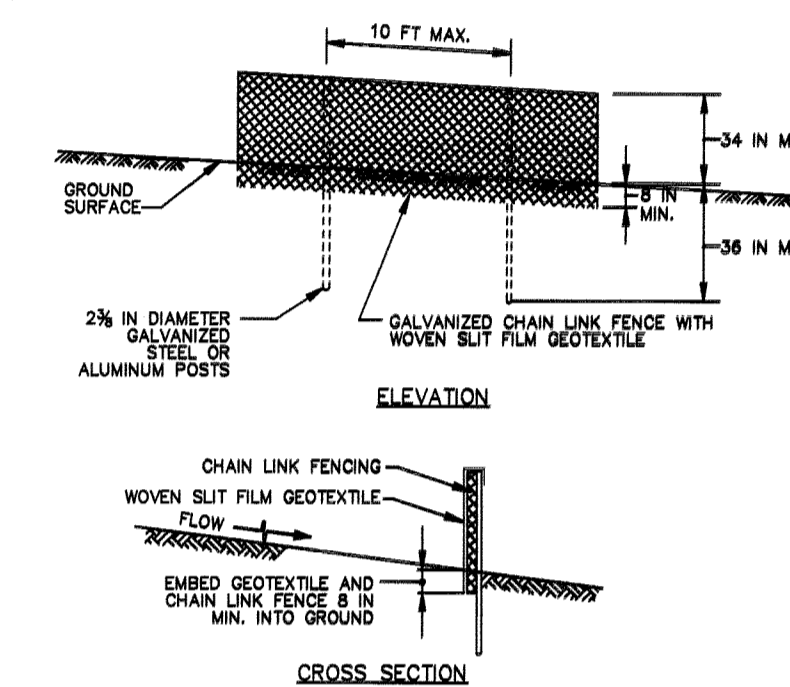

CONSTRUCTION SPECIFICATIONS

- INSTALL 2 1/2 INCH DIAMETER GALVANIZED STEEL POSTS OF 0.085 INCH WALL THICKNESS AND SIX FOOT LENGTH SPACED NO FURTHER THAN 10 FEET APART. DRIVE THE POSTS A MINIMUM OF 36 INCHES INTO THE GROUND.
- FASTEN 8 GAUGE OR HEAVIER GALVANIZED CHAIN LINK FENCE (2 1/2 INCH MAXIMUM OPENING) 42 INCHES IN HEIGHT SECURELY TO THE FENCE POSTS WITH WIRE TIES OR HUG RINGS.
- FASTEN WOVEN SILT FILM GEOTEXTILE AS SPECIFIED IN SECTION H-1 MATERIALS, SECURELY TO THE UPSLOPE SIDE OF CHAIN LINK FENCE WITH TIES SPACED EVERY 24 INCHES AT THE TOP AND MID SECTION. EMBED GEOTEXTILE AND CHAIN LINK FENCE A MINIMUM OF 8 INCHES INTO THE GROUND.
- WHERE ENDS OF THE GEOTEXTILE COME TOGETHER, THE ENDS SHALL BE OVERLAPPED BY 6 INCHES, FOLDED, AND STAPLED TO PREVENT SEDIMENT BY PASS.
- EXTEND BOTH ENDS OF THE SUPER SILT FENCE A MINIMUM OF FIVE HORIZONTAL FEET UPSLOPE AT 45 DEGREES TO THE MAIN FENCE ALIGNMENT TO PREVENT RUNOFF FROM GOING AROUND THE ENDS OF THE SUPER SILT FENCE.
- PROVIDE MANUFACTURER CERTIFICATION TO THE INSPECTION/ENFORCEMENT AUTHORITY SHOWING THAT GEOTEXTILE USED MEETS THE REQUIREMENTS IN SECTION H-1 MATERIALS.
- REMOVE ACCUMULATED SEDIMENT AND DEBRIS WHEN BULGES DEVELOP IN FENCE OR WHEN SEDIMENT REACHES 25% OF FENCE HEIGHT. REPLACE GEOTEXTILE IF TORN. IF UNDERMINING OCCURS, REINSTALL CHAIN LINK FENCING AND GEOTEXTILE.

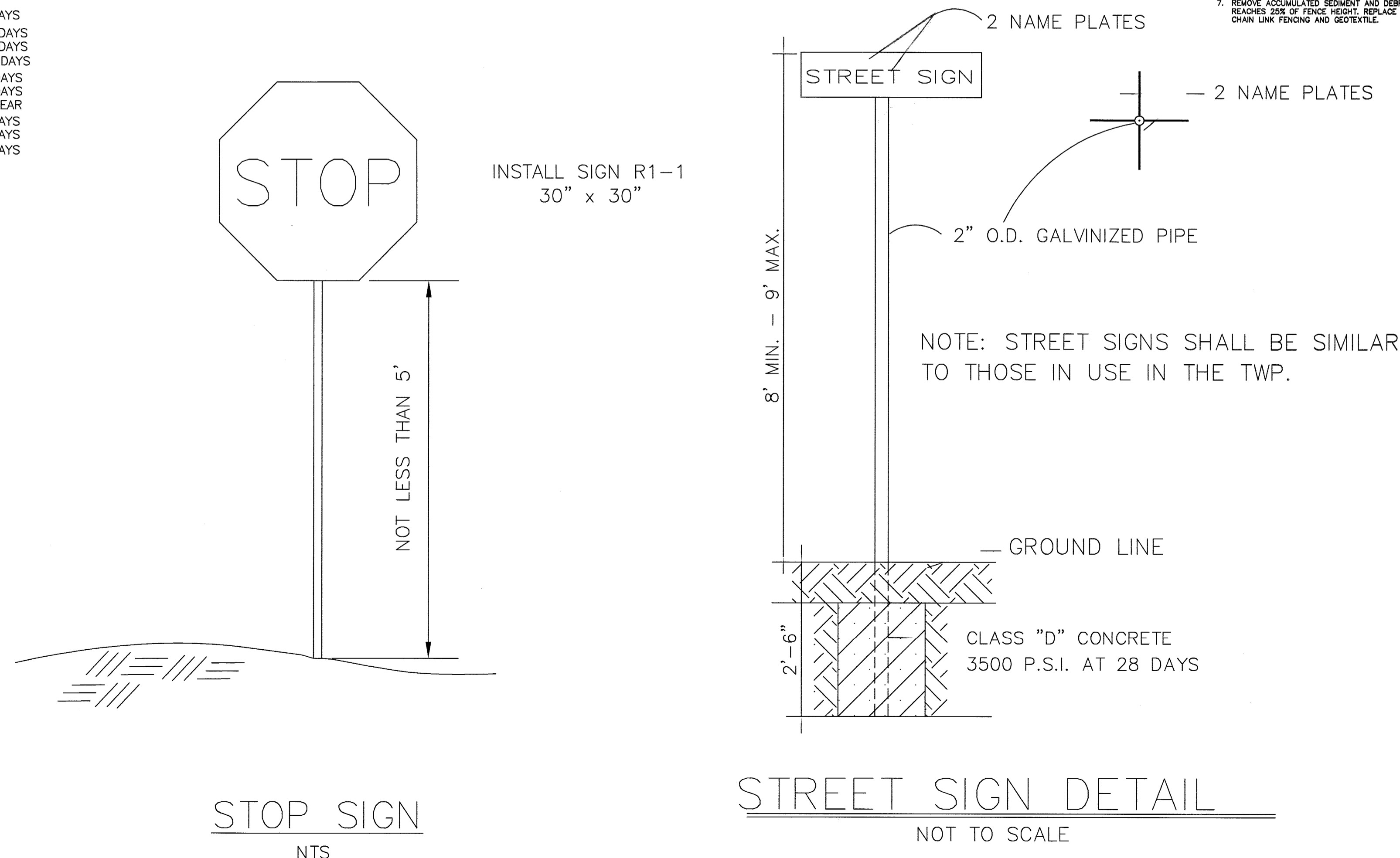

STOP SIGN
N.T.S.

STREET SIGN DETAIL
NOT TO SCALE

DRAWN BY: SP CHECKED BY: WGH

JOB No. 14-026

BOOK

SCALE N.T.S.

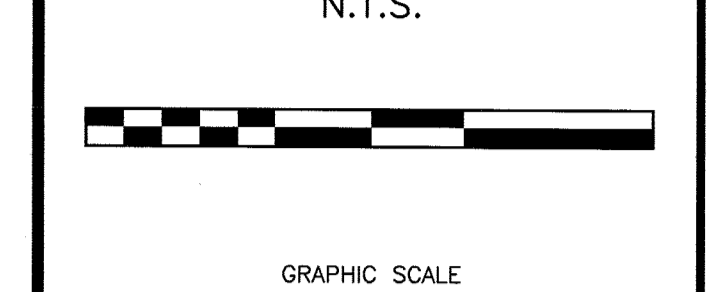

DATE APRIL 30, 2021

REVISIONS OCTOBER 20, 2021

CERTIFICATE OF AUTHORIZATION
No. 24GA27959700

NOTES

Murphy & Hollows Associates LLC
CIVIL ENGINEERING AND SURVEYING
331 ELM STREET, STIRLING, NJ 07980
908.580.1255 murphyhollows@gmail.com

FINAL MAJOR SUBDIVISION PLAN
WESTMINSTER PRESBYTERIAN CHURCH
LOT 32 BLOCK 2006
MOUNTAIN AVENUE &
PLAINFIELD AVENUE
TOWNSHIP OF
BERKELEY HEIGHTS
UNION COUNTY
NEW JERSEY
CONSTRUCTION DETAILS

AIDAN T. MURPHY
N.J. LIC. PROFESSIONAL ENGINEER #21319
N.J. PROFESSIONAL PLANNER #2531

William G. Hollows
WILLIAM G. HOLLOWES
N.J. LIC. PROFESSIONAL ENGINEER
& LAND SURVEYOR #27473
N.J. PROFESSIONAL PLANNER #2530

FILE	SHEET
LF14-026	13
	OF
	13